



Ro

Design Mia Cullin
Production year 2020

Room divider with painted aluminum structure available in two versions; modules covered in leather or wood and rotate independently. The structure of the separ  is available in the free-standing version, with standard dimensions and in the wall version, with 3 standard dimensions and the possibility of adapting to your spaces.

Options for structure

- BI** Glossy white
- BO** Matt white
- BR** Bronze painted
- GF** Graphite painted
- NO** Matt black
- NS** Semi-bright black
- PG** Pearl grey
- CH** Champagne
- OR** Gold painted

Covering finishing available

- CPF** Full grain leather (30 colors)
- CTT** Contract leather (18 colors)
- RW** Oak dyed weng 
- NC** Walnut Canaletto
- FG** Grey ash
- FR** Natural ash
- FS** Bleached ash
- FN** Black ash

Technical information

Cod.ACC.200.9.FS

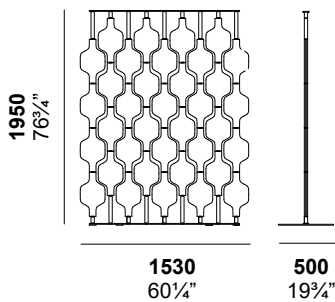

Cod.ACC.200.6

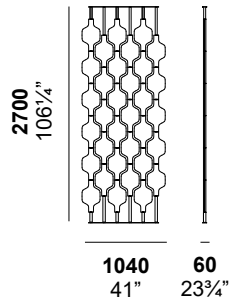

Cod.ACC.200.9

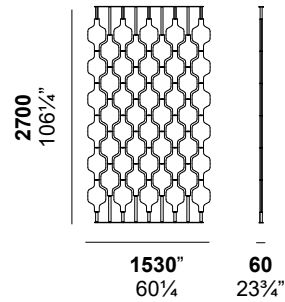

Cod.ACC.200.12

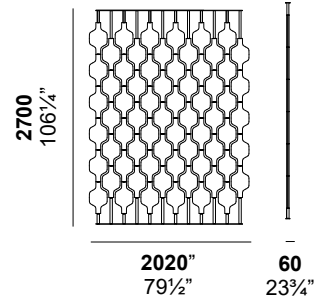

All measurements in
millimetres and inches

Design

STUDIO NOVE.3



Mia Cullin studied at Konstfack, University College of Arts, Crafts and Design, as well as abroad at the Denmark Design School in Copenhagen and at Accademia di Moda e Design in Florence. She founded her design studio after having graduated from Konstfack in 1998. Her works span from interior design to furniture and smaller objects. A deeply nourished interest in traditional craftsmanship and visually striking constructions inspires Mia Cullin's work with interior architecture work as well as with design objects in all kind of sizes. Clean, straightforward and often basic geometric shapes are combined with handcraft details.



Ro

Design Mia Cullin
Anno di produzione 2020

Parete divisoria da interni con struttura in alluminio verniciata disponibile in due versioni; moduli che ruotano in modo indipendente rivestiti in cuoio o in essenza. La struttura del separé è disponibile nella versione free-standing, con dimensioni standard e nella versione a muro, con 3 dimensioni standard e la possibilità di adattarlo ai propri spazi.

Struttura disponibile
BI bianco lucido
BO bianco opaco
BR verniciato bronzo
CH champagne
GF verniciato grafite
NO nero opaco
NS nero semilucido
OR verniciato oro
PG grigio perla

Materiali di rivestimento disponibili
CPF cuoio pieno fiore (30 colori)
CTT cuoio contract (18 colori)
FR frassino naturale
FS frassino sbiancato
FG frassino grigio
FN frassino nero
NC noce canaletto
RW rovere tinto wengé

Informazioni tecniche

Cod.ACC.200.9.FS

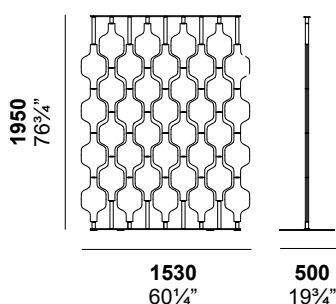

Cod.ACC.200.6

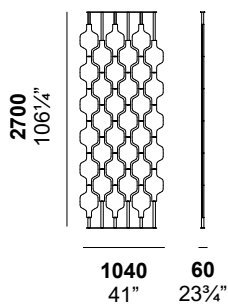

Cod.ACC.200.9

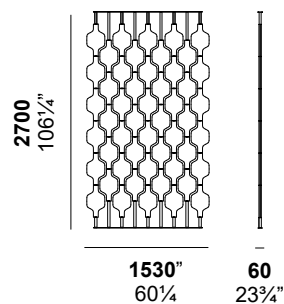

Cod.ACC.200.12

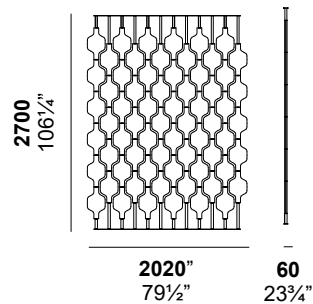

Le misure riportate sono in
millimetri e inches.

Design

STUDIO NOVE.3



Mia Cullin ha studiato al Konstfack, University College of Arts, Crafts and Design, oltre che all'estero presso la Denmark Design School di Copenhagen e all'Accademia di Moda e Design di Firenze. Ha fondato il suo studio di design dopo essersi laureata alla Konstfack nel 1998. Le sue opere spaziano dall'interior design ai mobili e agli oggetti più piccoli. Un interesse profondamente nutrito per l'artigianato tradizionale e le costruzioni visivamente suggestive ispira il lavoro di Mia Cullin con il lavoro di architettura d'interni e con oggetti di design di ogni tipo di dimensione. Le forme geometriche pulite, semplici e spesso di base sono combinate con dettagli artigianali.