



Web President high back

Cod.10.0113
Design Design Fauciglietti Engineering
Production year 1999

Swivel armchair with inner steel frame, expanded polyurethane padding and covered with different material options. Gas seat height adjustment and tilt control mechanism (basic Synchro).

Painted options for legs

- AL** - Liquid aluminium
- CR** - Bright chrome
- NS** - Semi-bright black

Covering finishings for shell

- COM** - Material provided by the customer
- FE** - Felt (60 colors)
- FX** - Faux leather (45 colors)
- PPF** - Soft full grain leather (60 colors)
- IM** - Innovative material

To check the available colors, consult the finishing catalogue.

Technical information

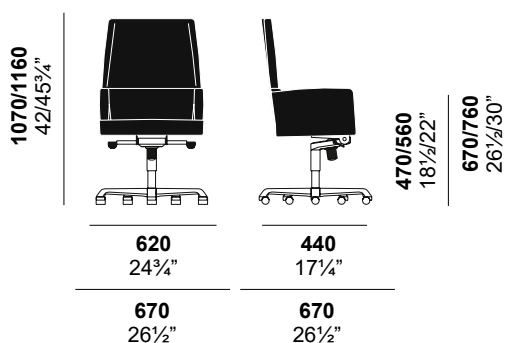

Dimensions
72 x 72 x 112 cm
28½ x 28½ x 44 inches



Net weight 19 kg/ 41.8 lb
Gross weight 21 kg/ 46.2 lb

Type Carton



Volume 0.528 m³

All measurements in
millimetres and inches

Design
Fauciglietti
Engineering



Fauciglietti Engineering studio was founded in 1986 by Renzo Fauciglietti together with his wife Graziella Bianchi: the aim was "the search and development of new products of design as well as their planning and their production". The prizes and awards they have received (Tecnhotel in Genoa, Compasso d'Oro, Neste Form in Finland, the silver medal at Batimat in Paris) are the result of a constant job of research and innovation in the product development. Furthermore Renzo Fauciglietti is teacher at Centro di Cultura Scientifica "Alessandro Volta" in Como and university lecturer at Politecnico and Bocconi in Milan.



Web President alta

Cod.10.0113

Design Design Fauciglietti Engineering

Anno di produzione 1999

Poltrona girevole con struttura portante in metallo, schiumato in poliuretano espanso e rivestimento disponibile in diverse opzioni. Meccanismo di regolazione altezza seduta a gas e basculante (basic Synchro).

Finiture verniciate disponibili per gambe

AL - Alluminio liquido

CR - Cromo lucido

NS - Nero semilucido

Materiali di rivestimento disponibili

COM - Materiale fornito dal cliente

FE - Feltro (60 colori)

FX - Ecopelle (45 colori)

PPF - Pelle pieno fiore (60 colori)

IM - Materiale innovativo

Per verificare i colori disponibili consultare la scheda finiture.

Info tecniche

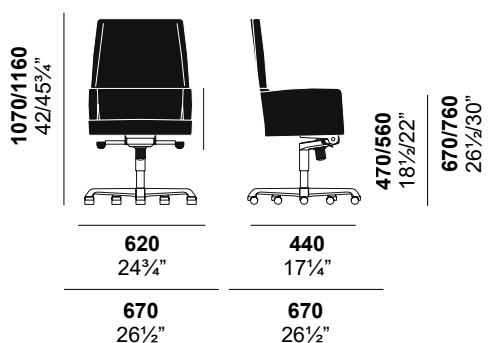

Dimensioni

72 x 72 x 112 cm

28½ x 28½ x 44 inches

Tipo Cartone



Peso netto 19 kg/ 41.8 lb

Peso lordo 21 kg/ 46.2 lb



Volume 0.528 m³

Le misure riportate sono in
millimetri e inches.

Design

Fauciglietti
Engineering



Lo studio Fauciglietti Engineering viene fondato nel 1986 da Renzo Fauciglietti insieme alla moglie Graziella Bianchi: l'intento è "contribuire alla ricerca ed allo sviluppo di nuovi prodotti di design, alla loro progettazione ed alla loro creazione". Il premio Technotel di Genova, le segnalazioni al Compasso d'oro ed al NESTE Forma Finlandia, la medaglia d'argento al Batimat di Parigi sono i risultati di un lavoro costante di ricerca e di innovazione nello sviluppo del prodotto, un impegno al quale si affianca l'attività di docenza al Centro di Cultura Scientifica "Alessandro Volta" di Como, al Politecnico di Milano e all'Università degli Studi "Bocconi" di Milano.