



Studio Nove.3

Luca Giacomelli and Lorenzo Rossotti both born in 1993, graduated in Product Design at the European Institute of Design in Milan in 2015. Since 2015 they have been collaborating with design studios in Milan also working in the field of packaging. In 2018 they founded together Design Studio Nove.3 in Milan, dealing with product design and design consulting. In the meantime, they take part in some contests with the studio, receiving international awards from important companies in the furniture sector.

Luca Giacomelli e Lorenzo Rossotti, nati nel 1993, si sono laureati in Product Design presso l'Istituto Europeo di Design di Milano nel 2015. Dal 2015 collaborano con studi di design a Milano lavorando anche nel campo del packaging. Nel 2018 hanno fondato il Design Studio Nove.3 a Milano, occupandosi di design del prodotto e consulenza progettuale. Nel frattempo, partecipano ad alcuni concorsi con lo studio, ricevendo premi internazionali da importanti aziende del settore dell'arredamento.



butterflytable

The elegant base shows its lightness through the glass top. It leans on two sinuous leather elements that remind butterfly wings.

La raffinata base esprime grande leggerezza grazie al piano in vetro che si posa su due sinuosi elementi a forma di ali di farfalla, sapientemente rivestiti in cuoio.



CODE40.0902
STRUCTURECTT200
TOPVEF

butterflydesk

This desk is a design item with actual shapes. The leather top version creates a work corner for domestic spaces, whereas the glass top version is perfect for working areas. The shapes of the desk make it a sort of architectural building characterized by symmetry and strength.

La scrivania si presenta come un oggetto di design dalle forme molto attuali. La versione con top in cuoio ricrea un angolo di lavoro all'interno dello spazio domestico, mentre la versione con top in vetro è perfetta per gli ambienti di lavoro. La configurazione della scrivania la rende quasi una costruzione architettonica fondata sulla staticità e sulla simmetria.



CODE40.0904
BASE/TOP CPF27
MODESTYPANEL BR

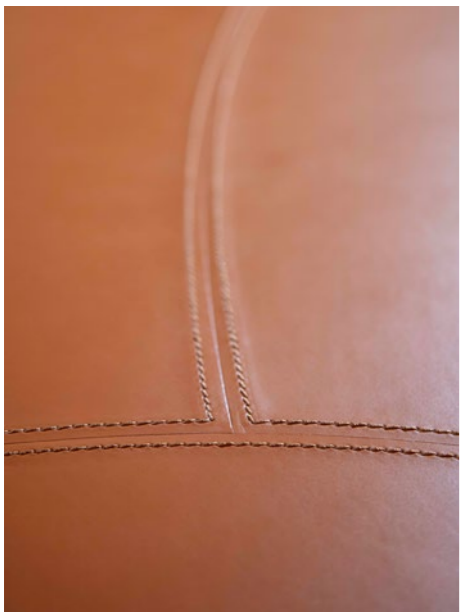

butterflydesk



CODE40.0904
 BASE/TOP CPF27
 MODESTYPANEL BR

technical features

DESK

Desk with folded sheet metal structure covered in leather.
 Top in leather, glass or wood + leather.
 Seams on the leather top as indicated in the drawing.
 Modesty in lacquered sheet metal.

structure finishing

CPF full grain leather (30 colors available)
CTT contract leather (15 colors available)

top finishing

CPF full grain leather (30 colors available)
CTT contract leather (15 colors available)
VET transparent crystal glass
VEF fumé gray crystal glass
VBR bronze crystal glass
NC walnut Canaletto + CPF/CTT (in the middle)

modesty panel finishing

BR bronze painted
GF graphite painted
NO matt black

TABLE

Table with folded sheet metal structure covered in leather. Top in glass available in various colors.

structure finishing

CPF full grain leather (30 colors available)
CTT contract leather (15 colors available)

glass top finishing

VET transparent crystal glass
VEF fumé gray crystal glass
VBR bronze crystal glass

SCRIVANIA

Scrivania con struttura in lamiera piegata rivestita in cuoio. Piano disponibile in vetro, rivestito completamente in cuoio o in essenza con rivestimento centrale in cuoio. Cuciture sul top come indicate nel disegno. Pannello modesty in lamiera laccata.

finitura struttura

CPF cuoio pieno fiore (30 colori disponibili)
CTT cuoio contract (15 colori disponibili)

finitura piano

CPF cuoio pieno fiore (30 colori disponibili)
CTT cuoio contract (15 colori disponibili)
VET cristallo trasparente
VEF cristallo fumé
VBR cristallo bronzato
NC noce Canaletto + CPF/CTT (nel mezzo)

finitura pannello modesty

BR verniciato bronzo
GF verniciato grafite
NO nero opaco

TAVOLO

Tavolo con struttura in lamiera piegata rivestita in cuoio. Top rivestito in vetro in diverse finiture disponibili.

finitura struttura

CPF cuoio pieno fiore (30 colori disponibili)
CTT cuoio contract (15 colori disponibili)

finitura piano in vetro

VET cristallo trasparente
VEF cristallo fumé
VBR cristallo bronzato



The excellence Made in Italy

"Enrico Pellizzoni" brand was created in 1986 from a tradition in leather production that had spanned almost one hundred years. Since the early 1900s, the Pellizzoni family had made of leather their passion, initially entering the footwear sector but immediately repositioning themselves in furnishings. The company is traditionally based in Mariano Comense (Como - Italy) and has been established in its current 4,000 sq. m. complex since 1988, where essential residential and office furnishings are produced: chairs, armchairs, stools, sofas, tables, desks, cabinets and beds.

Il marchio Enrico Pellizzoni nasce nel 1986, dopo un'esperienza di lavorazione del cuoio centenaria. Fin dal 1900 infatti la famiglia Pellizzoni ha fatto del cuoio una vera passione; entra inizialmente nel settore calzaturiero orientandosi poi nella produzione di articoli d'arredo. L'azienda storicamente situata in Mariano Comense (Co), dal 1988 si è stabilita nel suo attuale complesso di 4000 mq, dove produce complementi d'arredo per la casa e l'ufficio: sedie, poltrone, sgabelli, divani, tavoli, scrivanie, contenitori, letti.

ENRICO PELLIZZONI s.r.l.
 VIA COMO 49
 22066 MARIANO COMENSE (CO) ITALY
 T. +39 031746286
 F. +39 031746256
 info@enicopellizzoni.com
 enricopellizzoni.com

**ENRICO
 PELLIZZONI®**

Butterfly series: all measurements in millimetres and inches / tutte le misure sono in millimetri e pollici

desk
 40.0904

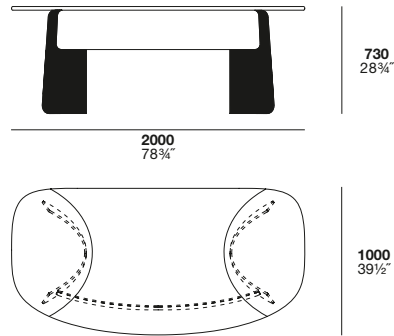

table round
 40.0902

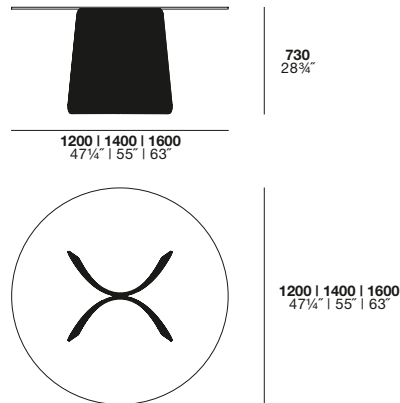

table rectangular
 40.0903

